

Spreader

X4

A spreader is one of the most important tools of a rescuer. Strangely enough it is one of the most misunderstood tools. When purchasing a spreader many make decisions on maximum force and opening. Please don't, as that is not why you buy a spreader! Let us explain further: A spreader is used to open structures with a small gap or opening. You need progressive power at the beginning of your spreading action, as that is where a structure is toughest and the opening is at its smallest – not at the end of the spread. Furthermore a spreader can easily be designed to have a 90-degree angle for a very large opening, but above 63-degrees a spreader will start to pull itself into the structure instead of spread. It is all about effective performance and doing the job the best, not just what looks good on paper. The Spreader X4 is the highest performing spreader on the market if you know what you're looking for.

Features:

- UltimatePressure
- EWOTECHNOLOGY

Facts:

- Best power to weight ratio
- Most powerful spreader on the market
- Progressive power line at the start
- Effective working angle of 63 degrees

EWOTECHNOLOGY

**PRESSURE
ULTIMATE**

X4 Spreader: the highest performing spreader if you know what you're looking for

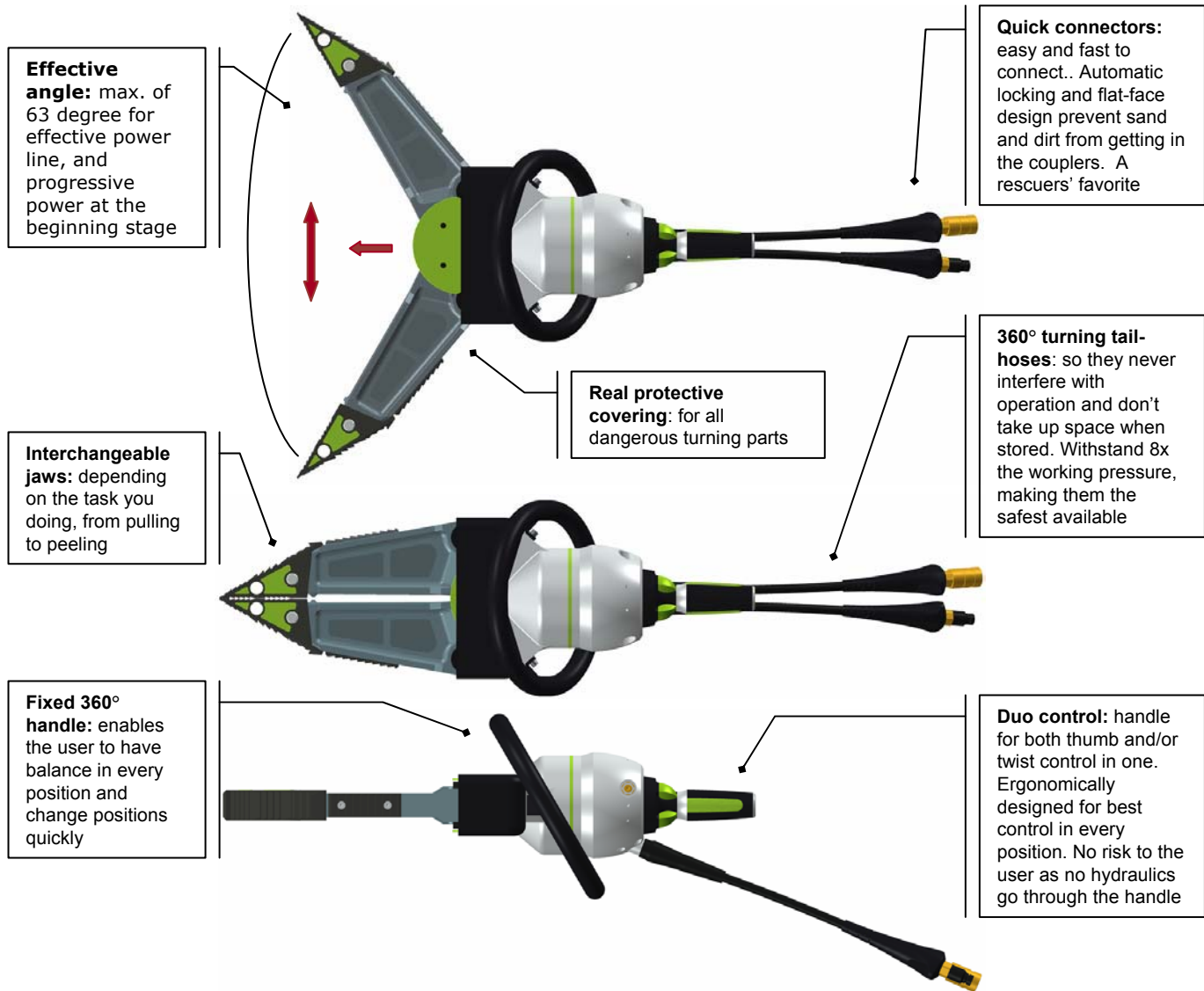

Spreader X-series

Technical specifications X4

| | |
|------------------------|--|
| Model | X4 Spreader |
| Nominal pressure | UltimatePSI™ / 5000 PSI / 350 Bar |
| Dimensions (LxWxH) | 30 15/16" x 11 7/16" x 10 7/8" // 786 x 290 x 277 mm |
| Operational weight | 46.1 lb / 20.9 kg |
| Max. spreading opening | 27 1/8" / 690 mm |
| Spreading force | 226,980 lbs / 113.5 US tons 1010 kN / 103 ton |
| Max. pulling opening | 20 13/16" / 529 mm |
| Max. pulling force | 16,383 lbs / 8.2 US tons 72.9 kN / 7.4 ton |
| EN 13204 | Compliant |
| NFPA 1936 | Compliant |
| | |
| | |

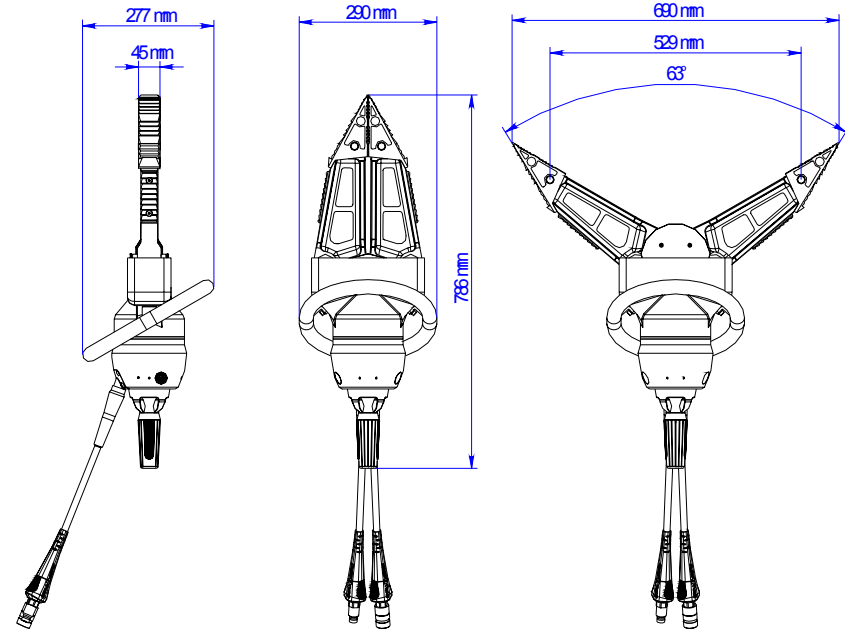

For questions or additional information please e-mail to info@resqtec.pl / info@ratownictwo.com.pl

DS012K00

RESQTEC®

RESQTEC® is a registered trademark

© RESQTEC® 2007
Technical modifications reserved

P.T.H."COMPART" - Z.Dziembowski, Centrum Sprzetu Ratowniczego
PL 44-121 Gliwice , ul. Gen.J.Sowinskiego 5 (IMN)
Tel./ Fax +48 (0) 32 - 2 380 680 , 2 380 436 , e-mail : info@resqtec.pl
www.resqtec.pl / www.ratownictwo.com.pl / www.998.info.pl